

Please tape down

Please tape down

3rd Fold

Affix
Stamp



NewTeam Ltd.

Customer Service Dept.
Brunel Road
Earlstrees Industrial Estate
Corby
Northants
NN17 4JW

1st Fold

2nd Fold

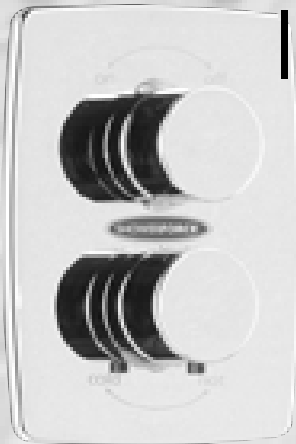

Installation Instructions and User Guide

**SHOWERFORCE 904-T
THERMOSTATIC MIXER SHOWER**

**IN THE EVENT OF ANY QUERY PLEASE CONTACT
THE NEWTEAM CUSTOMER HELPLINE**

Tel : 01536 264 012

SHOWERFORCE

**PLEASE KEEP THIS BOOKLET
FOR FUTURE REFERENCE**

**DEAR INSTALLER WHEN YOU HAVE READ THESE INSTRUCTIONS
PLEASE ENSURE YOU LEAVE THEM WITH THE USER**

ShowerForce 904-T

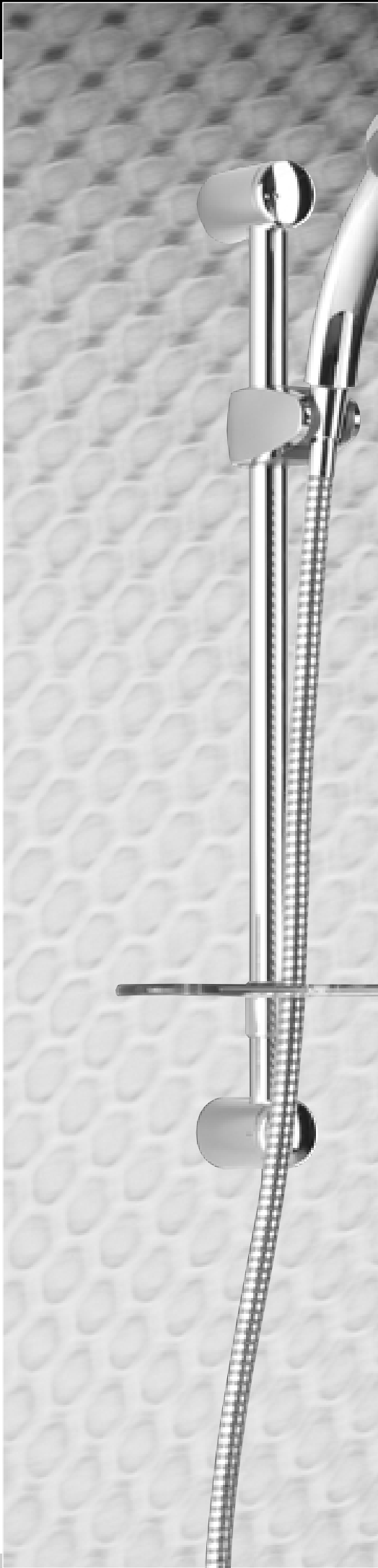

Contents

Installation and Operating Instructions for ShowerForce Thermostatic Mixer Shower

● 904-T

Please read this booklet carefully and ensure a competent person undertakes the installation.

Note: Following the headings in sequence will guide you through the installation and operation of your ShowerForce 904-T Mixer Shower.

	Pages
INTRODUCTION	3 - 4
• Site Requirement	
• General	
INSTALLATION	5 - 7
SERVICE/MAINTENANCE	8
GUARANTEE & REGISTRATION	9 - 10

Refer to back cover for Guarantee, Customer Service and Replacement Parts Policy. In the event of any query regarding installation please contact the NewTeam Customer Service Department

Tel: 01536 264 012 • Fax: 01536 409 201

E-mail: service@newteam.co.uk • E-mail: spares@newteam.co.uk

In line with our policy of continual product development the specifications may be varied and product design altered. We reserve the right to depart from the details given in this manual without prior notice.

904-T

Installation and operating instructions for the 904-T Thermostatic Mixer Shower.

The valve is supplied with the hot inlet on the left and the cold inlet on the right when viewed from the front. The hot supply must be connected to the inlet port marked 'H'.

Please read these instructions carefully, and ensure the shower valve is installed to The Water Supply (Water Fittings) Regulations. If in doubt, contact a registered plumber or the Secretary of Institute of Plumbing, address as follows:

Institute of Plumbing
64 Station Lane
Hornchurch
Essex
RM12 6NB

Tel: 01708 472 791

Site Requirements

To ensure the correct operation of your shower mixing valve it is important to fully understand your site installation. This thermostatic mixing valve will suit the following:

- Gravity Fed Hot & Cold (Equal Pressure)**
- Gravity Fed Hot & Mains Cold (Differential Pressure)**
- Unvented Systems**
- Gas Combination Boiler**
- Pumped System**

The shower mixing valve may require slight adjustment depending on your site installation the following may apply.

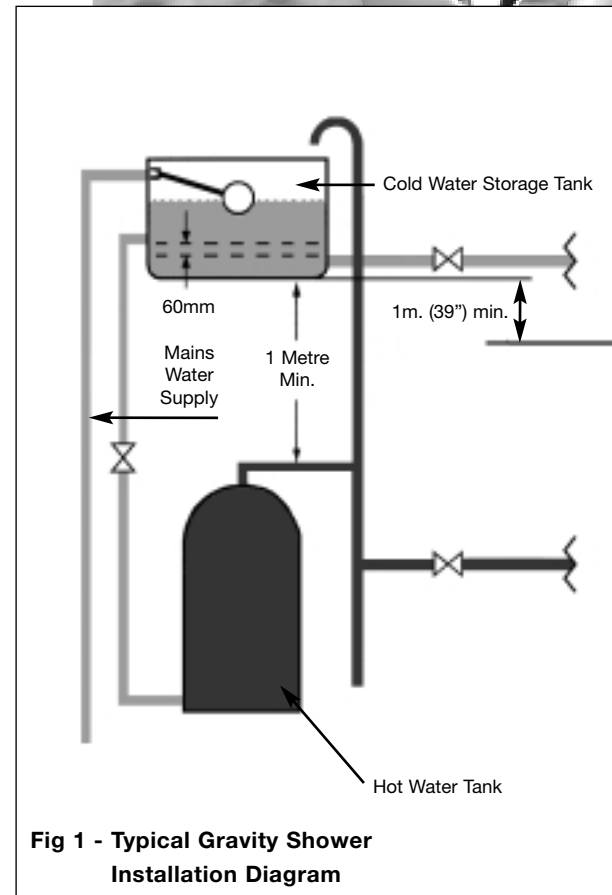

Fig 1 - Typical Gravity Shower Installation Diagram



General

GRAVITY FED

Fig 1 shows a typical layout. The distance between the bottom of the cold water tank and the shower head must be a minimum of 1 metre (0.1 bar).

Make the connection into the hot water supply pipe from the cylinder ensuring that it is the first draw off on the vertical pipe below the expansion pipe tee. If this is not possible a direct connection must be made from the hot water cylinder with an Essex flange.

The cold water supply should be taken directly from the cold water storage tank positioned 60mm below the cold connection which feeds the hot water cylinder.

The opposite installation is recommended for most showers, if however your cold supply is mains pressure then the following will be required.

INSTANTANEOUS GAS WATER HEATER & COMBINATION BOILER (UNVENTED)

The hot supply from the heater is to be connected to the hot inlet elbow and cold inlet elbow connected to the cold supply.

IMPORTANT: It is a requirement of Instantaneous Electric Water Heaters that a stable flow of water passes through the heater.

This requirement can be satisfied by using a Flow Stabiliser and should be adjusted to give a temperature of between 50 & 55°C from the heater.

Flow Stabilisers should be fitted prior to the heater.

PUMPED SHOWERS

Your Thermostatic shower is also ideal for power shower installation and can be matched to the ShowerForce range of shower pumps.

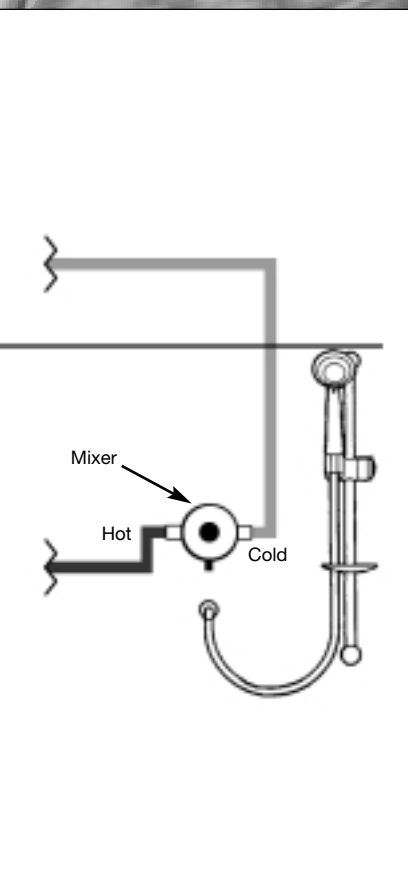

General

- 1) Before commencing it is advisable to install non-restrictive isolating valves on both hot and cold supplies for flushing out and servicing purpose.
- 2) It is important that both supply pipes are flushed before connecting mixing valves to ensure no pipe/plumbing debris enters the mixing valve.
- 3) A simple way of flushing out the pipes is to fit the outlet adaptor to the pipe and secure with the compression nut and olive, fit the hose to the adaptor and flush out pipes to the waste.
- 4) We recommend fitting the strainers to ensure no debris enters the mixing valve.
- 5) In hard water areas the mixing valve may require more frequent cleaning and servicing.
- 6) The temperature of your stored water must not exceed 65°C. A stored water temperature of 60°C is considered sufficient to meet all normal requirements in line with the British Standard 6700.

Specification

Inlet Connections: 15mm compression straight connectors.

Water Pressures: Min. 0.1 bar

Max. 5 bar

Max. Pressure ratio 5:1

Factory Set Maximum Outlet Temp: 42°C (can be re-set to suit site conditions)

Hot Supply Temp: Maximum recommended 65°C

Note: the inlet hot water temperature must be at least 10°C above the required blend temperature.

Fitting

PLEASE NOTE THAT THIS MIXER SHOWER CAN ONLY BE FITTED AS A RECESSED VALVE

It is essential that when installing a concealed mixing valve, full access to the valve can be achieved for servicing purposes. Rear access to the mixing valve is always preferred wherever possible (e.g. an airing cupboard or panelled walls), as this removes the need to disturb any tiling or decorating features at the front of the valve. Non-restricted isolation valve should be fitted on both supplies and ensure that they are accessible to maintain.

You must ensure a minimum depth of 60mm from the back of the valve to the finished surface (fig 3).

Prior to drilling into walls, check there are no hidden electrical wires, cables or water supply pipes with the aid of an electronic detector. If you use power tools do not forget:

- Wear eye protection
- Unplug equipment after use

Identify all components and check for completeness, particularly before arranging fitting.

Mark out the wall using the cover plate (4) as a template, mark around the outside and measure inside this line by approximately 15mm all round. This inside line is the shape of the aperture, which should be maintained as the wall is finished, to allow access to the valve and elbows for maintenance.

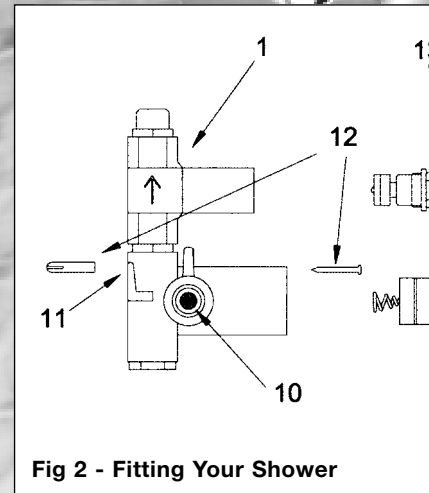

Fig 2 - Fitting Your Shower

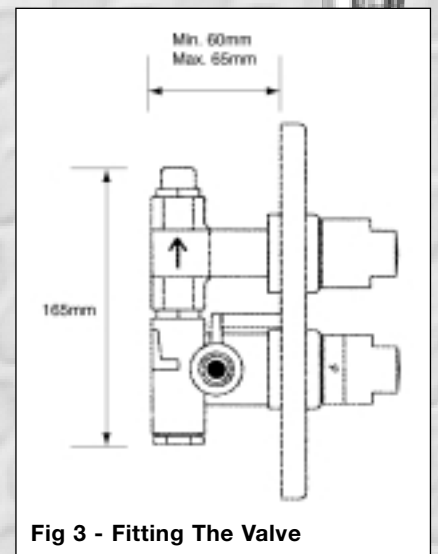

Fig 3 - Fitting The Valve

Fitting (Contd.)

Position the union elbow at convenient level and run intermediate pipework from valve to elbow. Fix pipework between mixer valve outlet nipple and shower union elbow, making the connection with 15mm tube (1/2" F.I BSP x 15mm elbow, not supplied). Attach hose to shower union using washer provided.

Determine correct orientation and position for the valve (1) and screw to supporting member or wall through the body lugs (11) with the screws and rawl plugs provided (12). Connect to the appropriate water supplies, **hot on the left and cold on the right, using suitably positioned elbows (supplied), and with the outlet on the top. Before connecting to the mixer, water should be flushed through the system to remove all debris.**

Ensure all openings in the wall are sealed against water ingress. The seal and fascia plate are for cosmetic purposes only.

The shrouds/covers (3), the flow control handle (5) and the temperature control handle (6) are all pre-assembled on the valve.

Place the concealing plate (4) over the valve.

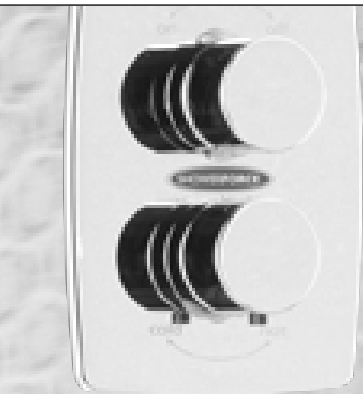
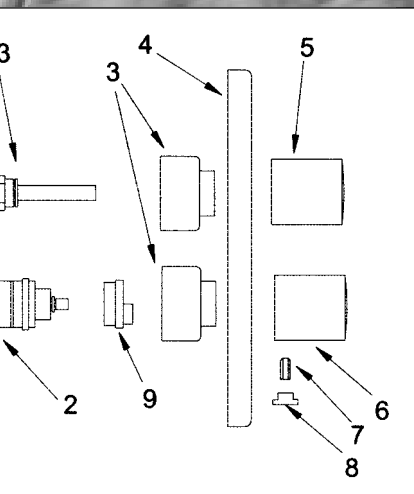

Operation and Setting

There are two control handles on this valve. To control the flow turn the handle (5) anti-clockwise to turn on and increase the flow., and clockwise to decrease and turn off. Turn the temperature control (6) anti-clockwise for hot and clockwise for cold. If in operation an increase in temperature above the factory set temperature is required, simply depress the red button on the temperature handle when it reaches the stop and continue to turn the handle anti-clockwise until the desired temperature is found. **Always return to the safe (42°C) setting after use, by rotating clockwise until the button clicks.**

The temperature stop is factory set at 42°C. This can however be adjusted for site conditions or personal preference by removing the handle indices (8) and unscrewing the retaining screw (7). Remove the temperature control handle (6) and turn the control spindle on the temperature valve in the required direction to increase or decrease the temperature. Replace the handle (6) so that the stop is in the maximum position. Screw the handle back onto the valve and replace the cover.

General Fault Diagnosis

If your valve fails to function correctly, the following should be checked:

- Check that the hot and cold connections are the correct way around. Hot on the left and cold on the right.
- Ensure that the hot water temperature is adequate, the recommended maximum temperature is 65°C. The hot water temperature should be at least 10°C higher than the blend temperature to ensure that the safety shut off will work.

Cleaning instructions

Do not at any time use bath cleaning liquids, powders or specified non-scratch cleaners on Surface finishes. In order to avoid surface wear on any of your shower fittings when cleaning, always use a damp cloth. For persistent stains or marks, you may use a domestic washing-up liquid.

Shower Rail Kit - Fig 4

Before proceeding with fitting the rail, identify each of the items supplied using the illustration.

No	Part Description
1	Rail end
2	Rail end caps
3 & 4	Rail with slider attached
5	Soap dish
6	Rail fixing screws & wall plugs

The slider must not be removed from the rail during fitting. The top of the slider has a smooth profile, whereas the underside has a recess revealing the grooves on the handset holder.

Fit the rail through the friction sleeve on the soap/gel dish with the sleeve towards the lower end of the rail.

Fit the rail ends onto the ends of the rail.

Position the rail on the wall, bearing in mind the heights of people likely to use the shower, and mark the wall to indicate the upper and lower fixing screw positions. Drill the wall at one of the marked fixing positions using a 6 mm drill. Loosely fix the appropriate rail end and check that the other fixing screw mark is in the correct position.

Secure the rail to the wall. Ensure that the rail is vertical before finally tightening both fixing screws.

Fit the rail end caps.

When fitting the hose, it should pass through the centre hole of the soap dish.

NOTE - The hose nut, and not the handset handle, fits into the slider, and the slider moves more freely on the rail, if gripped next to the rail rather than at the handset.

The fixings supplied are for use with solid walls. For fixing to plasterboard, suitable alternative fixings will be required.

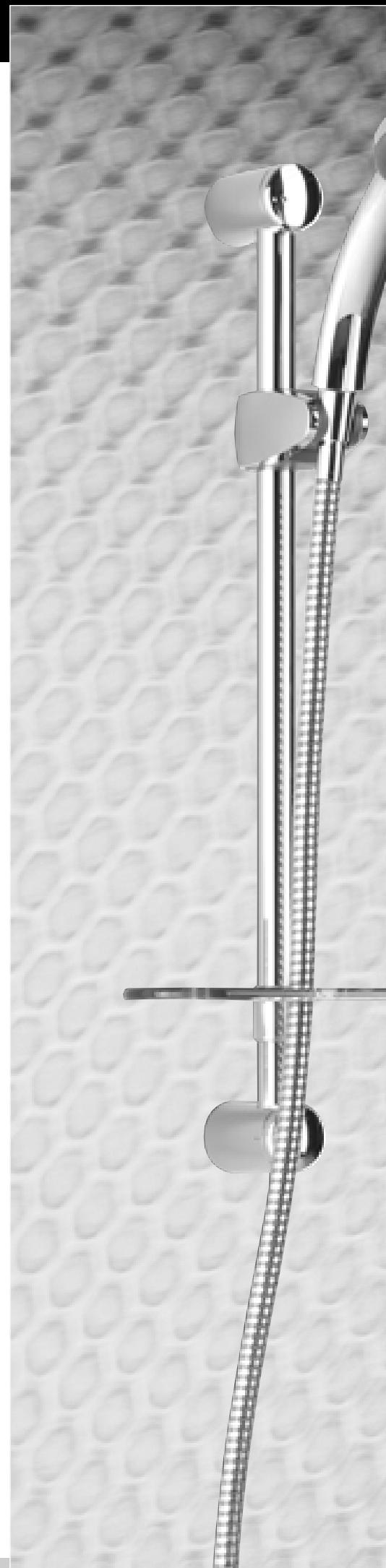
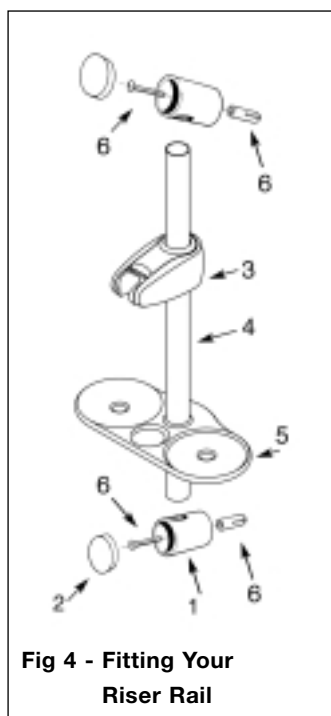

Service/Maintenance - Fig 2/5

We advise that the valve be regularly serviced, particularly in hard water areas. It is also important to clean the handset regularly in hard water areas to maintain an even spray/flow of water.

Unscrewing and pulling the cover plate away from the wall will reveal the valve and water connections. Removing straight connectors (17) and spacers (14 and 15) allows access to the filters (16) and check valves (14). The water supplies must be isolated remote from the valve before removal. The valve body is designed with flat sealing faces so that it can be removed without disturbing the supply pipes. If required, unscrew the mounting screws (12) and pull the body free. Should the valve need to be dismantled for cartridge maintenance then the procedure is:

- 1) Remove the temperature control handle (6), by removing indice cap (8) and unscrewing handle retaining screw (7).
- 2) Remove the black plastic ring (9) taking note of its position and unscrew the thermostatic cartridge (2) and clean with water to remove dirt.
- 3) Before reassembling the cartridge, clean its housing with a wet cloth and grease the O-rings on the cartridge using NewTeam Part No. SP-495-0002 (see table below).
- 4) Reassemble the cartridge and replace the black plastic ring in its original position. Reinstall body into cavity (if removed).
- 5) Turn on the water supply and, if necessary, reset the temperature. (See Operating & Setting on page 6).
- 6) Re-fit the handle and screw in position.
- 7) Repeat the cleaning operation for the flow control valve (13) if necessary.

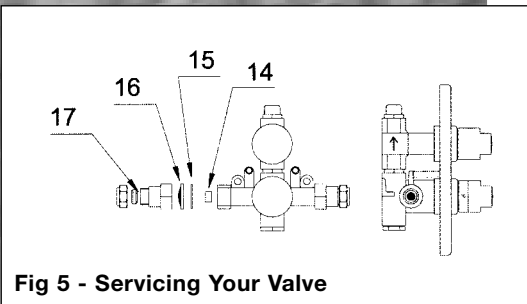
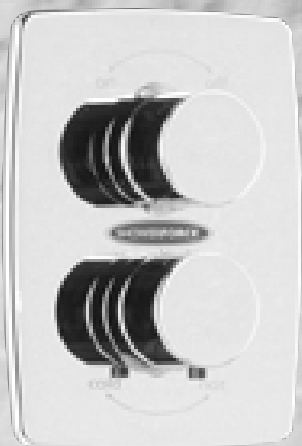

Fig 5 - Servicing Your Valve



Item No.	Description	Part No.
1	Locking Ring	SP-081-0510
2	Temperature Limit Stop	SP-081-0511
3	M5 x6 Grub Screw	SP-081-0512
4	Temperature Control Knob	SP-081-0513
5	Flow Control Knob	SP-081-0514
6	Locking Ring Securing Ring	SP-081-0515
7	Override Button	SP-081-0516
8	Valve Cover	SP-081-0517
9	Non Return Valve	SP-081-0518
10	Flow Control Valve	SP-081-0519
11	Thermostatic Cartridge	SP-081-0520
12	Cartridge Seating	SP-081-0521
13	Recess Shroud Seal	SP-081-0522
14	Recess Shroud	SP-081-0523
*	Complete Mixer Valve	SP-018-0020-CP
*	Rail Ends	SP-245-0001-CP
*	Rail & Slider	SP-280-0302-CP
*	Zag Handset	SP-168-0211-CP
*	Hose	SP-285-0113-CP
*	Sachet of Lubricant	SP-495-0002

* Not shown on diagram

Spare Parts

Fig 6 - SF 904-T

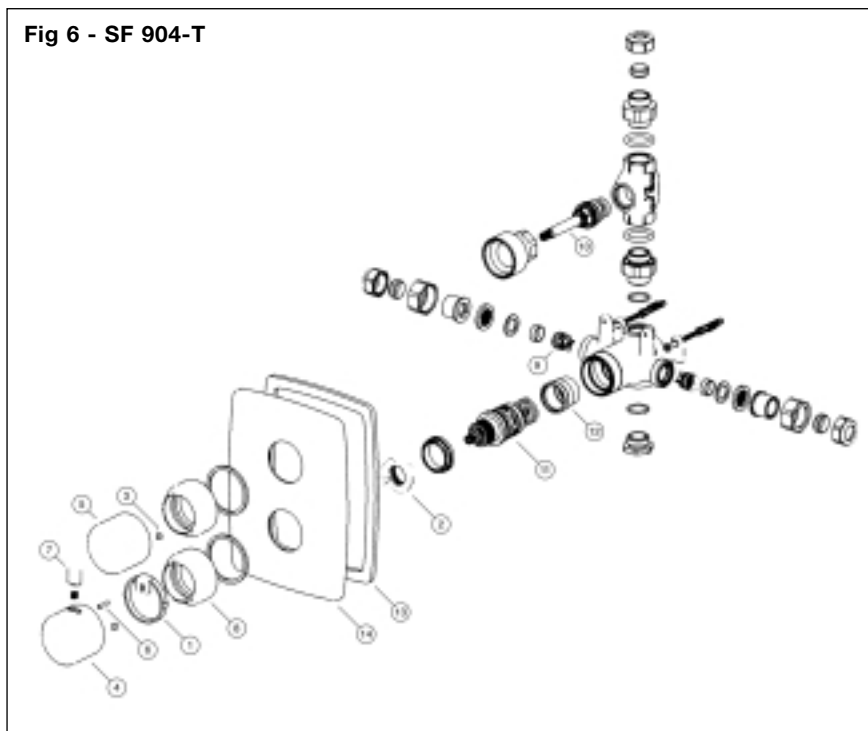

Guarantee

Thank you for purchasing a ShowerForce product, which has been designed, manufactured and tested, in the U.K., to the highest standards, by NewTeam Ltd.

Guarantee. 1 Year - Parts and Labour

This guarantee applies to products purchased within the United Kingdom or Republic of Ireland, but does not apply to products used commercially.

This is provided that:

1. The guarantee registration card is completed and returned within ten days complete with a copy of proof of purchase. Proof of purchase is required for any servicing requirements.
2. The product is installed and operated in accordance with our instructions and has not been misused or damaged.

This in no way affects your statutory rights as a consumer.

The information on the Guarantee card helps ShowerForce to process any claims and contact you about your product and its maintenance if required. The registration of your personal details is purely for Showerforce use, and the other information helps us to make products for the future.

ShowForce Shower products are designed, manufactured and tested to the highest standards.

Should a complaint arise, products are guaranteed against faulty workmanship and materials for a period of 12 months from the date of purchase, when in domestic use. For your guarantee to be valid, your shower must be installed by a competent person, in accordance with the instruction manual. Failure to do so will result in a service call charge being levied.

Home visits are made between 8.30am and 5.00pm Monday to Friday. Visits may be available outside these hours at our discretion, in which case a premium will be charged.

ShowForce will repair or replace (at our option), free of charge, any faulty components during the guarantee period, provided it has been maintained and operated in accordance with our instructions, and has not been misused or damaged.

Modification or repair of this product by person(s) not authorised by Showerforce will invalidate this guarantee.

This guarantee does not affect your statutory rights.

Service Policy - Replacement Parts Policy

IMPORTANT:

IN THE EVENT OF PRODUCT OR COMPONENT MALFUNCTION, DO NOT TAMPER WITH OR REMOVE THE PRODUCT FROM SITE. Telephone ShowerForce Customer Service Department on 01536 264 012 and be prepared with the date of purchase, model number and a description of the complaint.

Our service staff are fully qualified to advise on correct installation procedures and will be able to diagnose whether the fault will require a replacement part or a visit from a ShowerForce engineer.

If required, a service call will be booked, and either yourself or an appointed representative (who should be a person of 18 years or over) must be present during the visit.

All site visits to product within the guarantee period will be carried out free of any parts or labour charges provided the conditions of the guarantee have been adhered to.

All site visits to product out of guarantee will be subject to charges for parts and labour which is payable by you or your appointed representative at the time of the visit. Charges will also be levied on cancelled appointments, unless advised to ShowerForce at least 24 hours in advance of the agreed date and time.

We reserve the right not to undertake work where payment cannot be made to our engineer at the time of the visit.

ShowForce hold stocks of components for all their range of products and these will be maintained for the duration of their life.

Should a product be discontinued, spare parts stocks will be maintained, but in the event of a part becoming unavailable ShowerForce reserve the right to supply a substitute of equal quality.

The following payment methods can be used to obtain spare parts:

By post, pre-payment of proforma invoice by cheque or postal order.

By telephone quoting credit card (Mastercard, Visa or Visa Delta) details.

REPLACEMENT PARTS:

Tel: 01536 409 222 • Fax: 01536 409 201 • E-Mail:spares@newteam.co.uk

CUSTOMER SERVICE HOTLINE:

Tel: 01536 264 012 • Fax: 01536 409 201 • E-Mail:service@newteam.co.uk

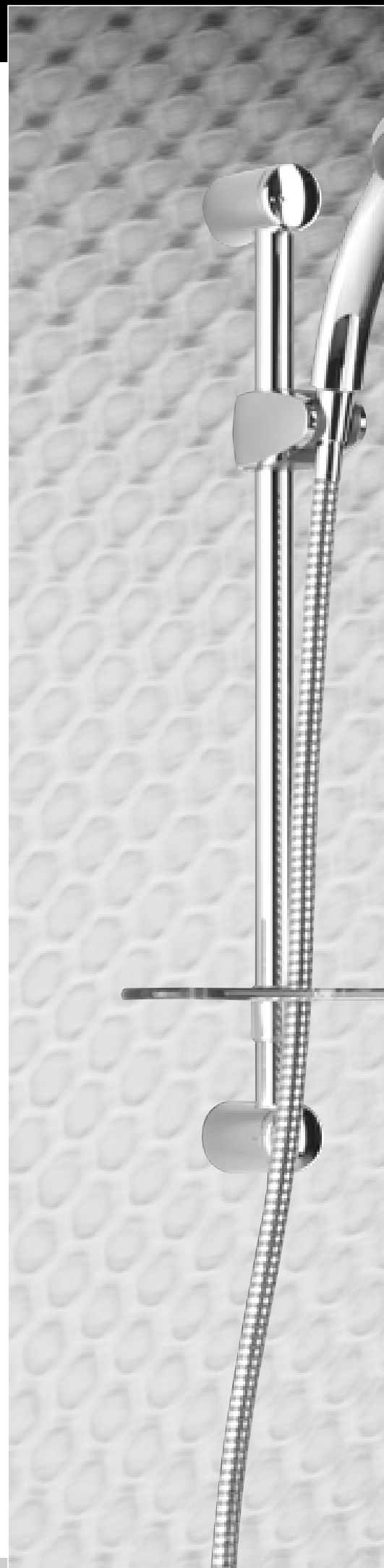

SHOWERFORCE

GUARANTEE CARD

Please post immediately enclosing a copy of proof of purchase

ShowerForce 904-T Mixer Shower

Proof of purchase enclosed

YES

NO

FOR SHOWERFORCE USE

AFFIX PRODUCT LABEL HERE

This label identifies your product and provides all the information needed

NAME:

ADDRESS:

POSTCODE:

DATE OF PURCHASE:

PRODUCT PURCHASED FROM:

TOWN:

ShowerForce/NewTeam's philosophy is to offer outstanding products with quality and integrity, please help us by taking the time to answer the following questions. Thank you.

MARKETING INFORMATION

1. Please state your profession: Plumber Builder Electrician Customer
Other (please specify) _____

2. Please state the reason for purchasing a shower: New Build Replacement
Renovation Other (please specify) _____

3. If the product is a replacement shower, please state the type and make of the shower it is replacing: _____

4. What influenced you to purchase the 904-T Mixer Shower? Advertisement
Trade Press Recommendation from Stockist Recommendation from Installer
Other (please specify) _____

5. Please state your main reason for purchasing the 904-T Mixer Shower:
ShowerForce Product Knowledge Product Features Product Styling Price
Other (please specify) _____

Please tick here if you do not require any further information or product updates from NewTeam

POST BACK

FOLD AND TAPE AS INSTRUCTED OVERLEAF